

# T Series 49

## Duplex Plunger Pumps, Solid Shaft

### FEATURES

- Forged brass manifold with an exclusive lifetime warranty
- Die-cast, anodized aluminum, oil-bath crankcase
- Solid ceramic plungers with continuously lubricated packings
- The original InterPump unitized stainless steel K01 inlet and outlet valves
- Ideal for drain cleaning and jetting applications
- Duplex pulsing action for improved impacted cleaning
- Also available in “L” left-handed and aluminum manifold versions

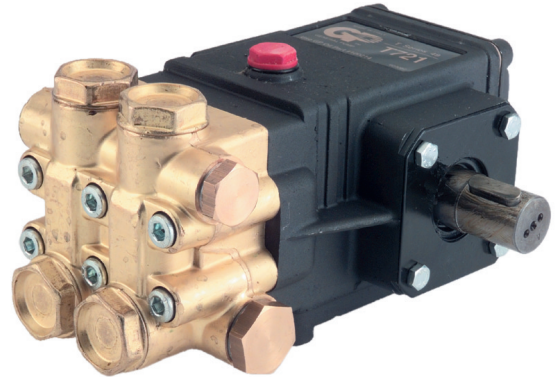

### SPECIFICATIONS

Pump Model	T721B	T731B	T9721B	T9731B
Maximum Volume	2.2 GPM	3.0/3.5 GPM	2.1 GPM	2.85 GPM
Maximum Discharge Pressure	1200 PSI	1200/1000 PSI	1000 PSI	1000 PSI
Maximum Pump Speed	1450 RPM	1450/1750 RPM	1750 RPM	1750 RPM
Maximum Inlet Pressure	125 PSI			
Maximum Inlet Vacuum	9 ft. water (7.9 in. Hg)			
Bore	.787 in. / 20 mm			
Stroke (in./mm)	.374 / 9.5	.472 / 12	.307 / 7.8	.414 / 10.5
Crankcase Oil Capacity	10.1 oz.			
Maximum Fluid Temperature	165°F			
Inlet Port Thread	1/2-14 BSPP-F			
Discharge Port Thread	3/8-19 BSPP-F			
Shaft Diameter	.945 in. / 24 mm			
Weight	11.0 lbs.			
Dimensions	8.8 x 6.8 x 5.4 in.			

*B=Brass*

# T Series 49 – Solid Shaft

**GENERAL PUMP** *A member of the Interpump Group*

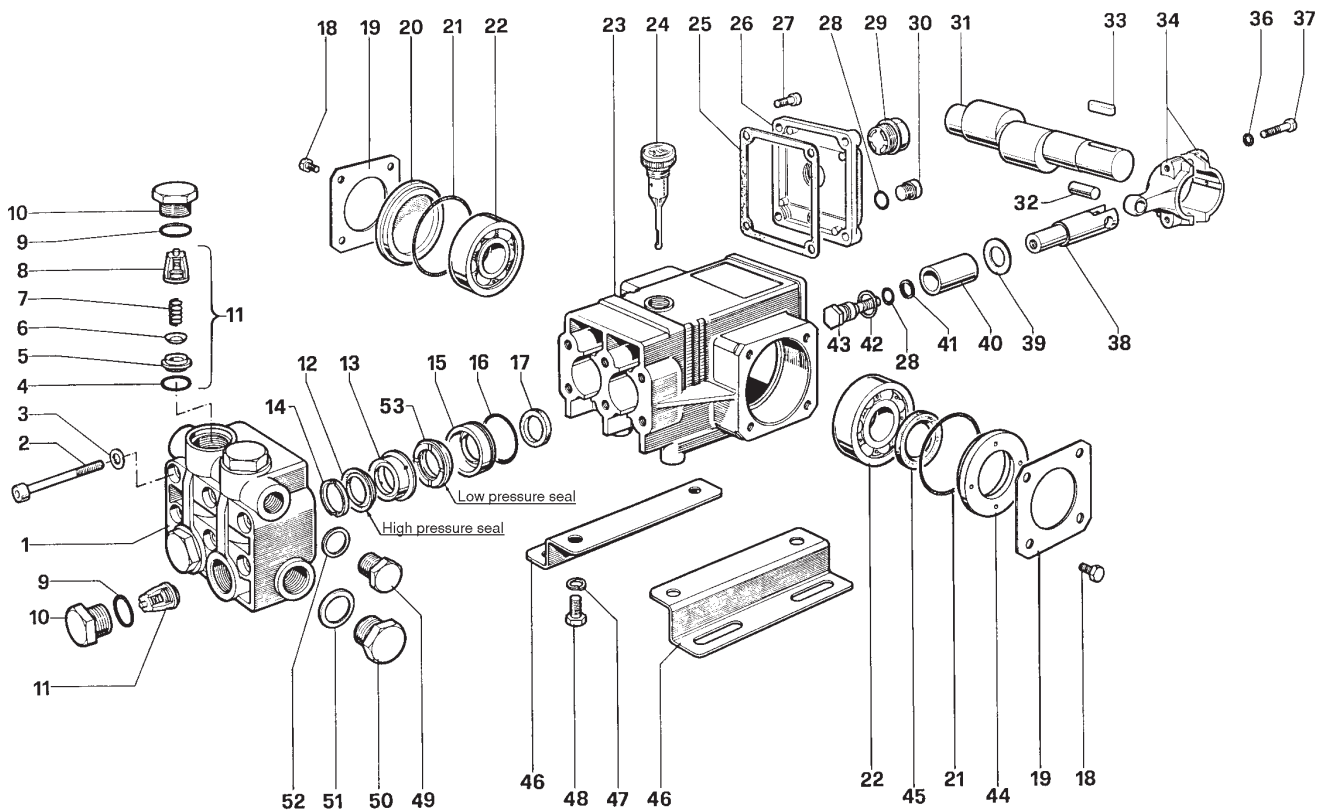

## PARTS LIST

ITEM	PART NO.	DESCRIPTION	KIT QTY.	ITEM	PART NO.	DESCRIPTION	KIT QTY.	ITEM	PART NO.	DESCRIPTION	KIT QTY.
1.	49.1200.22	Head, Pump, Aluminum	1	19.	50.1500.74	Cover, Crankcase	2	34.	50.0300.01	Rod, Connecting	2
	49.1200.41	Head, Pump, Brass	1	20.	50.2116.51	Spacer	1	36.	96.6939.00	Washer, M6.4 x 10 x .7	4
2.	99.3175.00	Screw, M8 x 60	6	21.	90.4097.00	O-Ring, 2.187 x .139	2	37.	99.1927.00	Screw, M6 x 35	4
3.	96.7014.00	Washer, M8.4 x 13 x 0.8	6	22.	91.8329.00	Bearing, Ball	2	38.	50.0500.56	Guide, Piston	2
4.	90.3841.00	O-Ring, .674 x .103	1 4	23.	49.0104.22	Crankcase	1	39.	96.7286.00	Washer, M14 x 28 x .5	6 2
5.	36.2003.66	Seat, Valve	1 4	24.	98.2103.00	Oil Dip Stick	1	40.	50.0404.09	Piston (20 mm)	2
6.	36.2001.76	Plate, Valve	1 4	25.	49.2119.84	Gasket, Cover	1	41.	90.5067.00	Ring, Back-up, .433 x .551 x .055	6 2
7.	94.7376.00	Spring	1 4	26.	49.1603.22	Cover, Crankcase	1	42.	96.7280.00	Washer, M14 x 18.5 x .5	6 2
8.	36.2002.51	Guide, Valve	1 4	27.	99.1837.00	Screw, M6 x 14	4	43.	47.2195.66	Screw, Piston	6 2
9.	90.3847.00	O-Ring, .797 x .103	4 4	28.	90.3585.00	O-Ring, .426 x .070	6 3	44.	50.2115.51	Spacer	1
10.	98.2220.00	Cap, M24 x 2 x 16	4 4	29.	97.5968.00	Indicator, Oil	1	45.	90.1634.00	Seal, Oil	1
11.	36.7032.01	Assembly, Valve	1 4	30.	98.2041.00	Cap, 1/4-BSPP	1	46.	50.2000.74	Feet, Pump	2
12.	90.2703.00	Packing	19, 27 2	31.	49.0204.35	Crankshaft (T721B)	1	47.	96.7016.00	Washer, M8.4	4
13.	50.2166.70	Ring, Intermediate	20, 27 2		49.0201.35	Crankshaft (T731B)	1	48.	99.3037.00	Screw, M8 x 16	4
14.	50.1000.51	Ring, Head	21, 27 2		49.0220.35	Crankshaft (T9721B)	1	49.	98.2100.00	Cap, 3/8-BSPP	1
15.	50.0805.70	Retainer, Packing	22, 27 2		49.0217.35	Crankshaft (T9731B)	1	50.	98.2176.00	Cap, 1/2-BSPP	1
16.	90.3612.00	O-Ring, 1.239 x .070	22, 27 2	32.	97.7330.00	Pin, Wrist	2	51.	96.7514.00	Washer, M21.5 x 27 x 1.5	1
17.	90.1614.00	Seal, Oil	23 2	33.	91.4878.00	Key	1	52.	96.7380.00	Washer, M17.5 x 23 x 1.5	1
18.	99.1807.00	Screw, M6 x 10	8					53.	90.2698.00	Seal, Low Press., 20mm 19,27	2

## REPAIR KITS

KIT NO.	1	4	6	19	20	21	22	23	27
ITEM NO'S INCLUDED IN KIT	4, 5, 6, 7, 8 (11)	9, 10	28, 39, 41, 42, 43	12, 53	13	14	15, 16	17	12, 13, 14, 15, 16, 53
NUMBER OF ASSEMBLIES IN KIT	6	6	3	3	3	6	3	3	1
NUMBER OF CYLINDERS KIT WILL SERVICE	3	3	-	3	3	3	3	3	1

## TORQUE SPECS\*

Position	Ft.-lbs.
2	14.7
10	73.7
18	7.3
27	7.3
29	13.2
30	14.7
37	8.8
43	14.7
48	14.7
49	5.1
50	29.4